

JR50/82

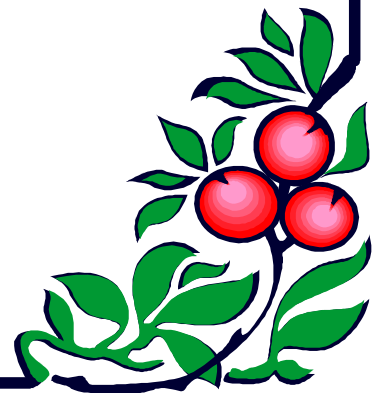

SERVICE MANUAL



§ CONTENTS §

PREFACE.....	Q1-1~ 1-2
ENGINE REMOVE.....	Q2-1~ 2-4
ENGINE INSTALLATION.....	Q 3-1~ 3-2
LUBRICATION SYSTEM.....	Q 4-1~ 4-2
FUEL SYSTEM.....	Q 5-1~ 5-4
CYLINDER HEAD/CYLINDER/PISTON.....	Q 6-1~ 6-6
TANSMISSION SYSTEM.....	Q 7-1~ 7-6
CRANKSHAFT/CRANKCASE.....	Q 8-1~ 8-4
A.C.G. EMERATOR	Q 9-1~ 9-2
ELECTRIC SYSTEM.....	Q10-1~10-6
CHASSIS.....	Q11-1~11-2

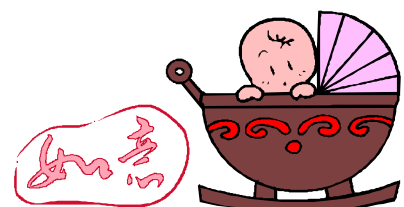

THE CONTENTS OF THIS MANUAL PROVIDE THE SERVICE INFORMATION FOR C.P.I JR50/90.

MOST CHAPTERS START WITH A SYSTEM OR ASSEMBLY ILLUSTRATION AND SPECIFICATIONS THE FOLLOWED PAGES GIVE DETAIL PROCEDURES.

IF YOU DO NOT KNOW WHAT THE SOURCE OF THE TROUBLE IS, PLEASE GO THE TROUBLESHOOTING FOR ADDITIONAL HELP.

ALL THE CONTENTS OF THIS MANUAL ARE BASED ON THE LATEST MODEL INFORMATION C.P.I RESERVE THE RIGHT TO MAKE CHANGE AT ANY TIME WITHOUT NOTICE AND WITHOUT ANY RESPONSIBILITY OR ENGAGEMENT ON OUR PART.

Remove the seat & the luggage box.
Remove the side covers.



Remove the luggage box.



Remove the side cover 2.



1.Remove the RR Luggage carrier comp.
2.Remove the side covers1.



Disconnect the Vacuum hose.1.
Disconnect the Fuel hose 1.
Disconnect the oil tube.
Disconnect the A.C.G wire.
Disconnect the start motor wive.
Disconnect the throttle valve.

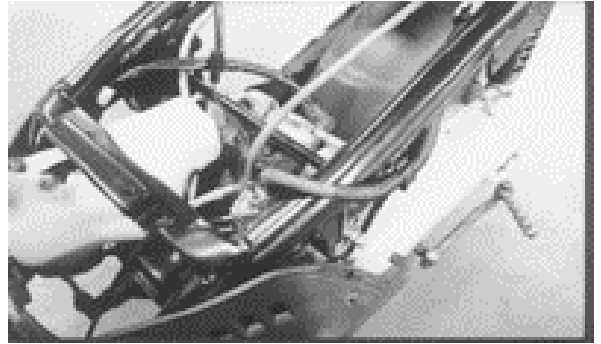

Disconnect the spark plug cap.

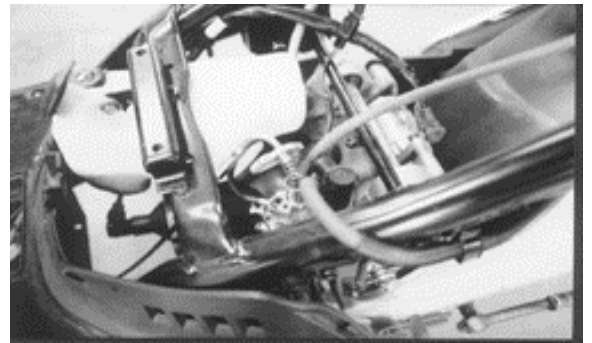

Disconnect the rear brake cable.



Remove the setting bolt of rear cushion.

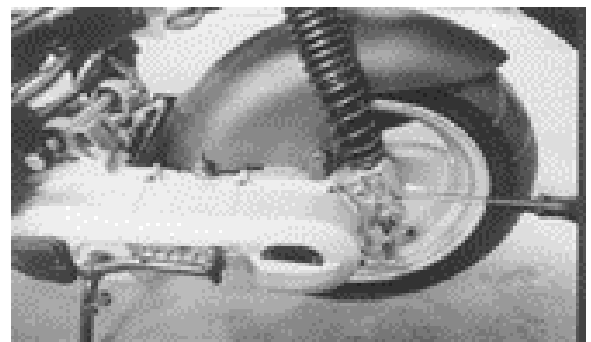

Remove the setting bolt of engine.

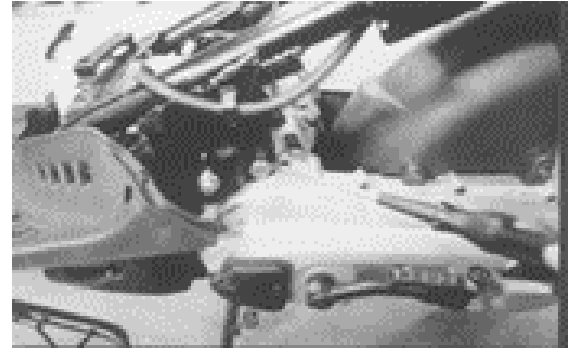

Remove the engine.



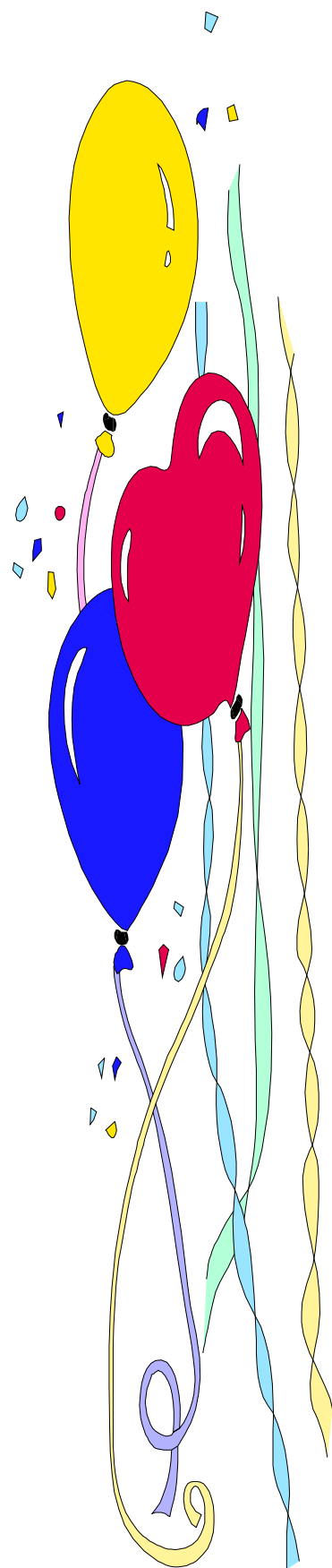

ENGINE INSTALLATION

The installation sequence is essentially the reverse of removal.

NOTE:

Route all the wire and cable properly.

Adjust the throttle cable free play.

Adjust the oil pump control cable

Clearance.

Adjust the rear brake free play.

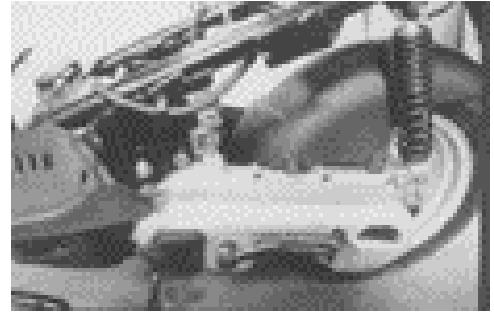

OIL PUMP REMOVAL

Remove the seat, luggage box, and side covers,

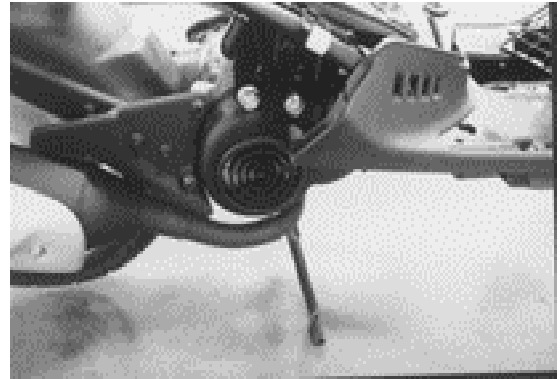

Remove the cooling fan cover ,cooling fan ,and A.C.G.

Disconnect the oil tube of oil tube of oil. Pump (intake and output).

Remove the oil pump control cable.

Remove the setting bolt of oil pump.

Remove the oil pump.

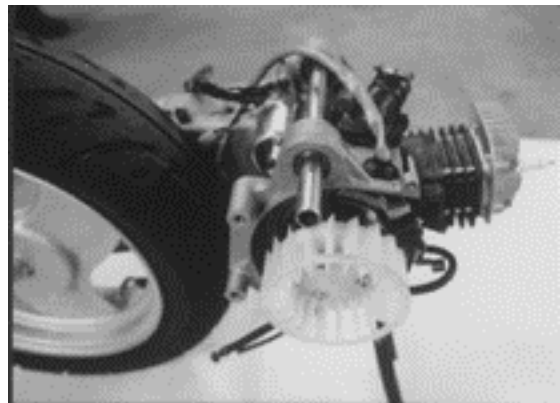

Oil pump inspection

Check the O-ring, gear & seal for wear or any damage.

NOTE:

Do not disassembly the oil pump body to prevent any damage.



OIL PUMP INSTALLATION

Coating some oil the O-ring.

Install the oil pump onto the crankcase.

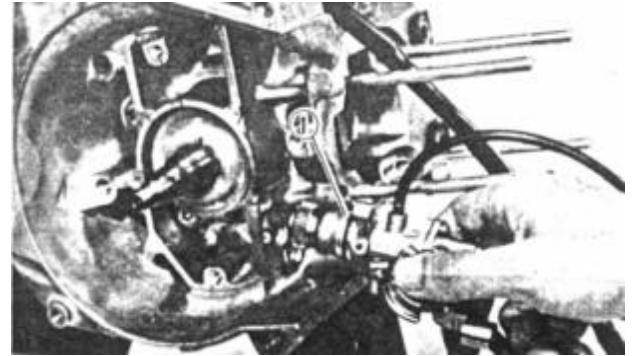

Connect the oil tube.

Connect the oil pump control cable and adjust the clearance.



RELEASE THE AIR OF OIL PUMP

Loosen the drain screw.

Let the oil drain out in smoothly then tight the screw.

NOTE:

If the oil can not drain out in smoothly, it is mean some air still in the oil pump.

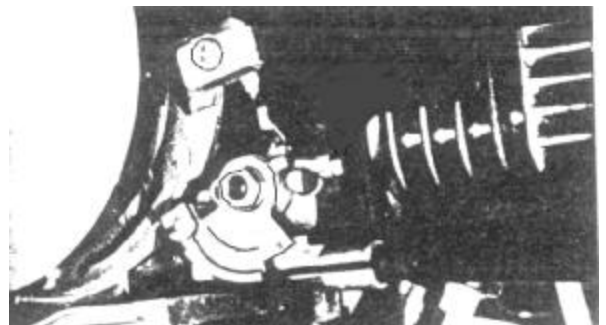

THROTTLE VALVE REMOVAL

Remove the seat.
Remove the luggage box.
Loose the carburetor cap.
Remove the throttle valve from the carburetor.

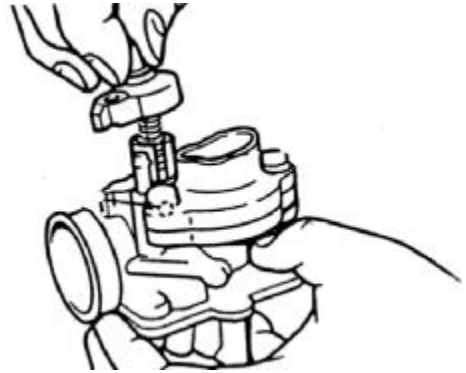

Remove the throttle valve from the throttle cable.



THROTTLE VALVE DISASSEMBLY

Remove the retainer and take out the jet needle clip from the throttle valve.

INSPECTION

Check the throttle valve and the jet needle surface of dirt, scratches or wear.

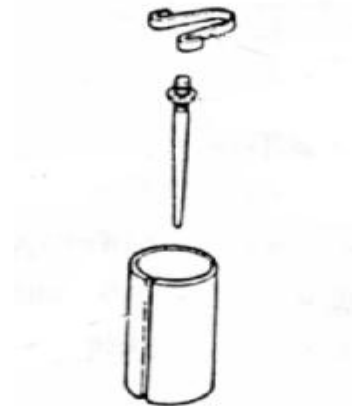

CARBURETOR REMOVAL

Remove the seat.
Remove the luggage box.
Remove the side cover.
Remove the starter plunger wire.
Remove the throttle cable.
Remove the fuel tube from the carburetor.
Loose the screw of the air cleaner band.
Loose the bolts between the intake pipe & the carburetor.
Remove the carburetor.



Remove the carburetor and let it cool down by nature for thirty minutes.
Check the current of air route as show.

GOOD : CHECKLESS

NG : CHECKED

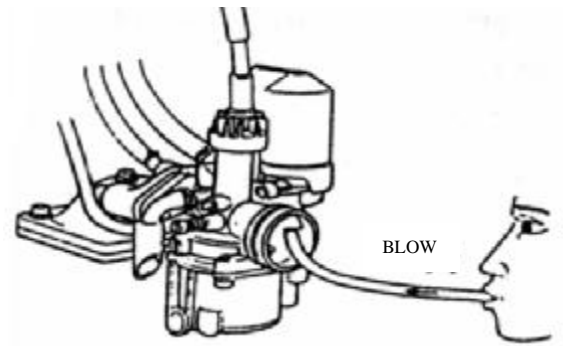

Connect a full charged battery to the starter plunger wore for five minutes.
Check the current of route as show.

GOOD : CHECKED

NG : CHECKLESS

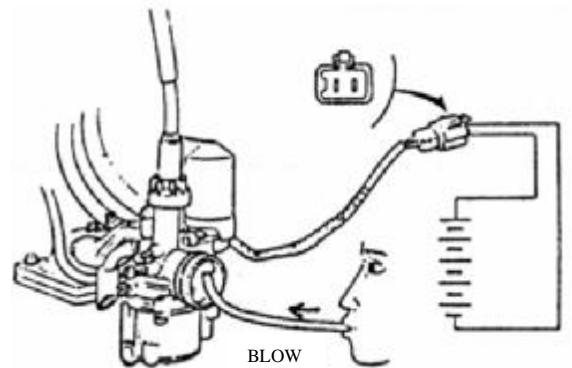

FLOAT CHAMBER DISASSEMBLY

Remove the setting screws.
Remove the chamber cap.



Remove the float setting bolt.
Remove the float pin.
Remove the float.
Remove the float valve.



Remove the main jet, slow jet, needle seat & air screw.
Clean all the jet & all the hole by using high pressure air.

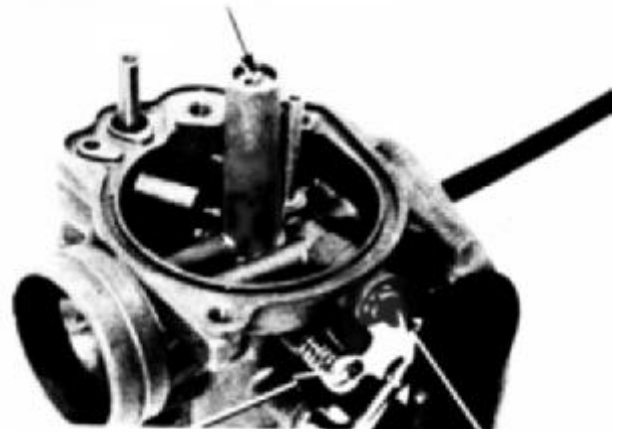

FUEL HEIGHT INSPECTION

Measure the height by using a gauge.
STANDARD: 18.5 mm



CARBURETOR INSTALLATION

The installation sequence is essentially the reverse of remove.



Adjust the clearance of the throttle valve cable.

Adjust the air screw.

STANDARD : $1\frac{1}{2} \pm \frac{1}{2}$ round

Adjust the idle speed.

STANDSRD: 1800± 100 rpm



REED VALVE REMOVAL

Remove the carburetor.
Remove the intake pipe.
Remove the reed valve.



REED VALVE INSPECTION

Measure the height of reed valve stopper.

STANDARD: 6.0-6.4 mm

Check the flatness of reed valve.

SERVICE LIMIT : 10 mm



REED VALVE INSTALLATION

The installation sequence is essentially the reverse of removal.



CYLINDER HEAD REMOVAL

- Remove the seat & the luggage box.
- Remove the spark plug cap.
- Remove the exhaust muffler.
- Remove the side covers.
- Remove the cylinder air shrouds.



- Remove the spark plug.
- Remove the setting bolts of cylinder head.
- Remove the cylinder head.



Cylinder head flatness inspection.
SERVICE LIMIT: 0.05 mm

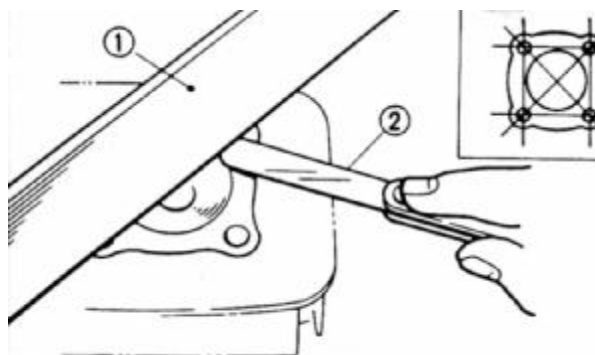

CYLINDER REMOVAL

- Remove the cylinder head.
- Remove the cylinder.
- Remove the cylinder gasket.

NOTE:

Clean all the material of cylinder gasket with a scraper.



PISTON REMOVAL

Remove the piston pin clip.

NOTE:

Do not let the clip fall into the crankcase.

Remove the piston pin.

Remove the piston.

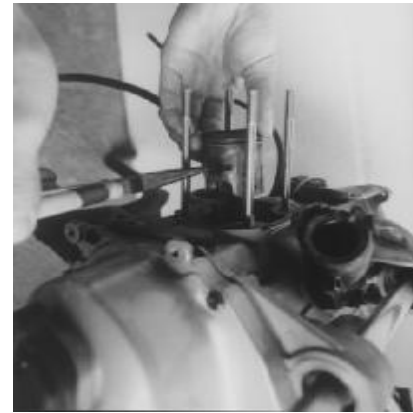

PISTON / PISTON RING INSPECTION

Remove the piston rings.

Clean the grooves for carbon deposit completely.

NOTE:

Do not damage the piston ring during removal.



Cylinder block flatness inspections:

SERVICE LIMITS: 0.05 mm



CYLINDER INSPECTION

Inspect the cylinder bore for wear or damage.

Measure the cylinder I. D. at three places; top, middle and bottom of piston travel and in two directions at right angle to each other.

SERVICE LIMITS: 40.2 mm

52.2 mm



Calculate the piston-to-cylinder clearance.

SERVICE LIMITS : 0.1 mm

Calculate the taper and out of round.

SERVICE LIMITS:

Out of round: 0.05 mm

Taper: 0.05 mm

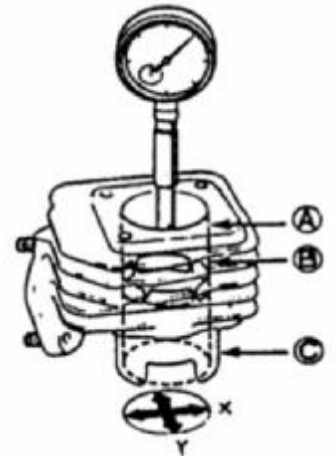

Measure piston pin bore O. D. at a point 10 mm from the bottom.

SERVICE LIMITS: 39.95 mm.

51.95 mm.

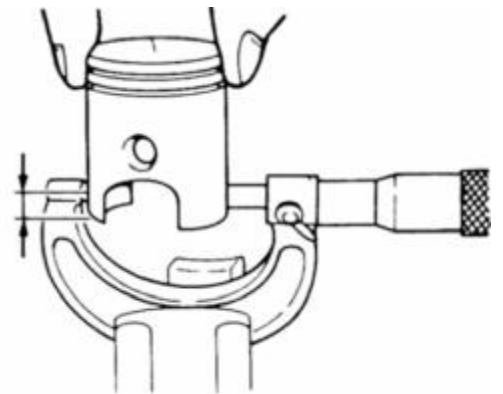

Measure piston pin bore I. D. in two directions at right angle to each other.

SERVICE LIMITS: 10.05 mm

12.05 mm

Measure the piston pin O. D. at the front, center and rear and in two directions across from each other.

SERVICE LIMIT: 9.95 mm

11.95 mm



Insert each piston ring into cylinder with the piston and measure the ring end gap in the cylinder to a point 10 mm (0.04 in) from the bottom.

SERVICE LIMITS:

Top / Second: 0.15~0.35 mm



Connecting rod small end inspections:

SERVICE LIMITS: 14.06 mm.

15.06 mm.

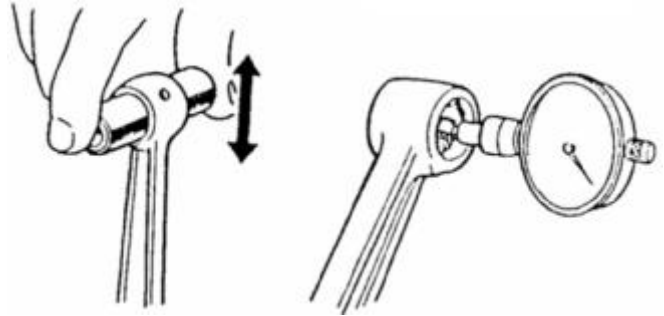

PISTON RING INSTALLATION

Clean the piston ring grooves thoroughly.
Install the piston ring.

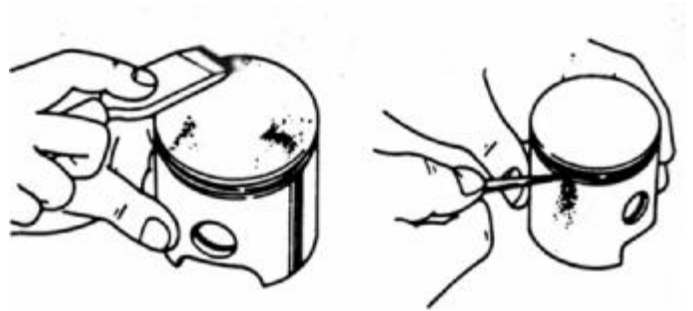

NOTE:

- i Avoid piston and piston ring damage during installation.
- i All ring should be installed with the mark facing up.

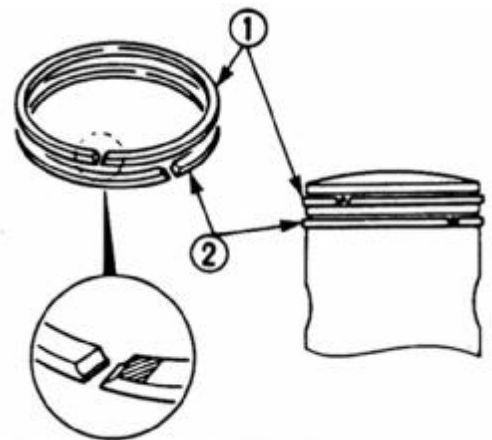

PISTON INSTALLATION

Install the piston, piston pin and new piston pin clips.

NOTE:

- i Piston the “EX” mark on the exhaust side.
- i Do not let the piston pin clip fall into the crankcase.



CYLINDER INSTALLATION

Install the cylinder gasket.

Coat the cylinder and piston ring with the engine oil.

Install the cylinder.



COMPRESSION PREASURE TEST

NOTE:

Warm up the engine before test.

Remove the seat & luggage box.

Remove the spark plug cap & spark plug.

Turn the throttle grip with the throttle valve on the upset position.

Start the motor for 7-8 seconds for test the pressure

STANDARD: 10.0 kg/cm² -600 rpm.

LEFT CRANKCASE COVER REMOVAC

Remove the start kick.

Left crankcase cover and dowel pin.

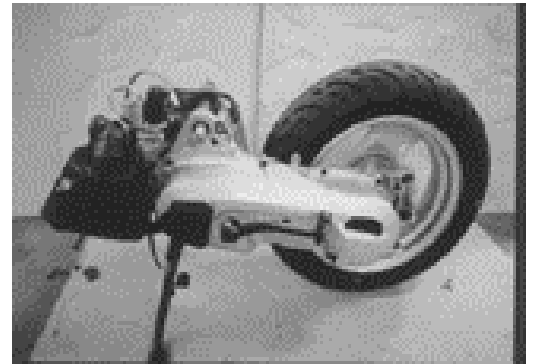

Remove the kick pinion with the kick friction spring.

Disconnect the kick start spring.

Remove the cir-clip, plate washer, kick spindle bush, and spring.

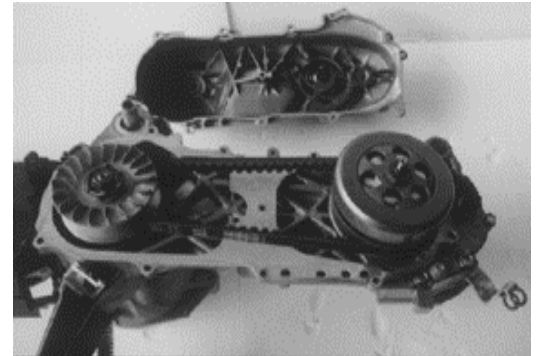

Remove the setting nut of clutch outer.

Remove the clutch outer.

Remove the driven pulley and drive beet.

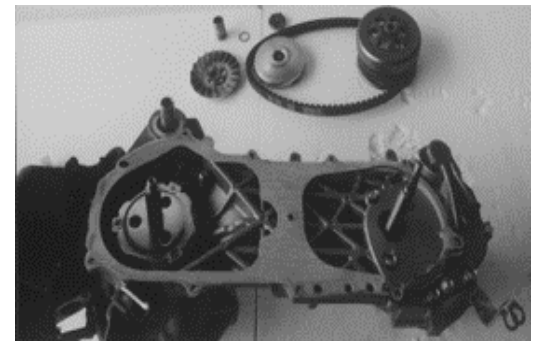

Remove the setting nut of driver face.

Remove the conical spring washer and the one way clutch.

Remove the claw washer, driver face and plat washer.

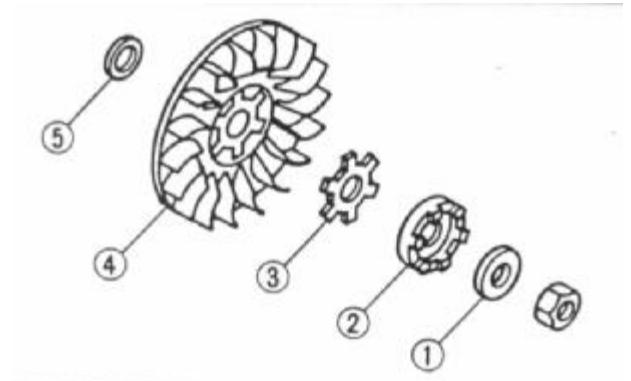

Remove the movable drive and collar.
Remove the starter clutch and starter wheel.
Remove the gear boss.
Remove the plat washer.
Remove the idle gear plate and idle gear.

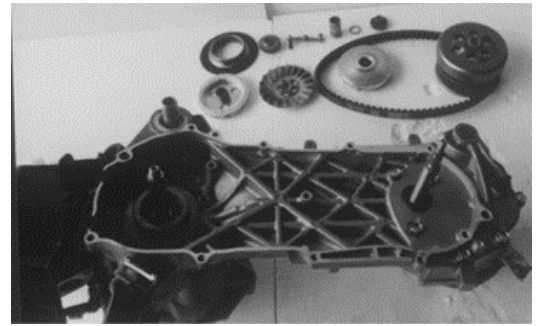

DRIVEN BELT INSPECTION

Inspect the belt for crack wear or any damage measure the width of belt.

SERVICE LIMIT : 14.6 mm

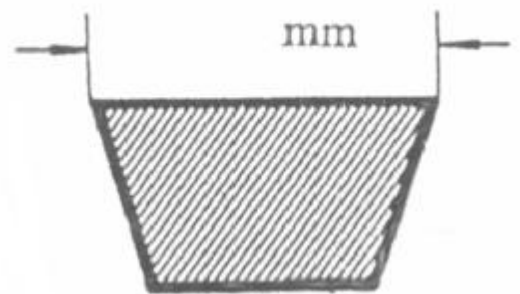

WEIGHT ROLLER INSPECTION

Measure the weight roller O. D.

SERVICE LIMIT : 14.5 mm

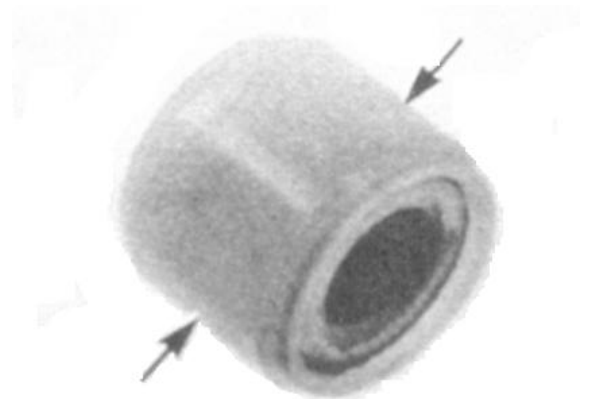

MOVABLE DRIVEN FACE INSPECTION

Measure the movable driven face I. D.

SERVICE LIMIT : 17.5 mm

20.5 mm



BOSS OF DRIVEN FACE INSPECTION

Measure the boss I. D.

SERVICE LIMIT : 23.94 mm

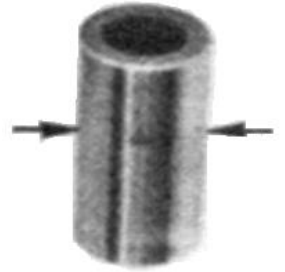

CLUTCH OUTER INSPECTION

Measure clutch outer I. D.

SERVICE LIMIT : 109.5 mm

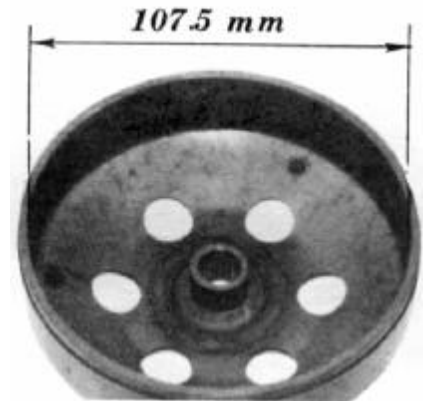

CLUTCH LINING INSPECTION

Measure the lining thickness.

SERVICE LIMIT : 1.5 mm

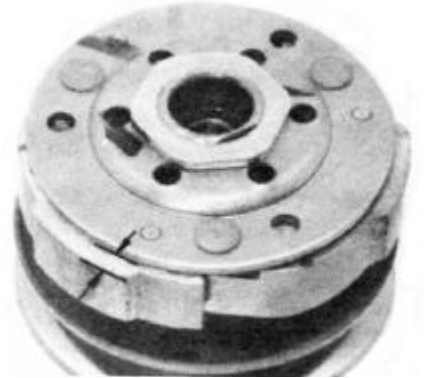

DRIVEN PULLEY DISASSEMBLY

Fix the driven pulley in a compressor.

Remove the special nut (28 mm).

Release the compressor.

Remove the driven plat assy.



DRIVEN FACE SPRING INSPECTION

Measure the spring free leant.

SERVICE LIMIT : 67 mm

89.5 mm

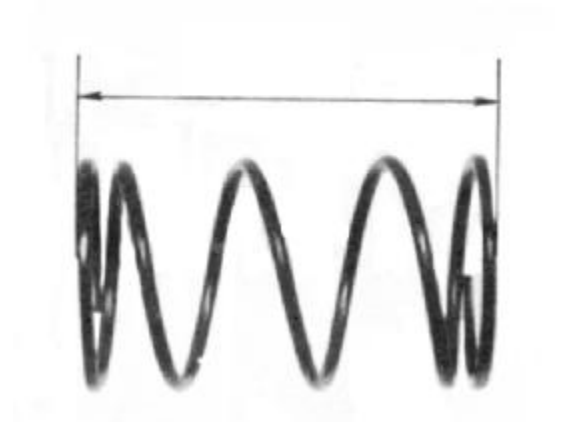

DRIVEN FACE INSPECTION

Measure the driven face O. D.

SERVICE LIMIT : 33.94 mm

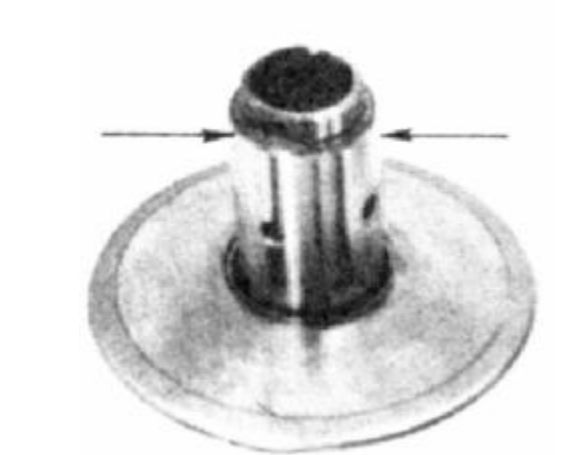

MOVABLE DRIVEN FACE INSPECTION

Measure the movable drive face I. D.

SERVICE LIMIT : 34.06 mm

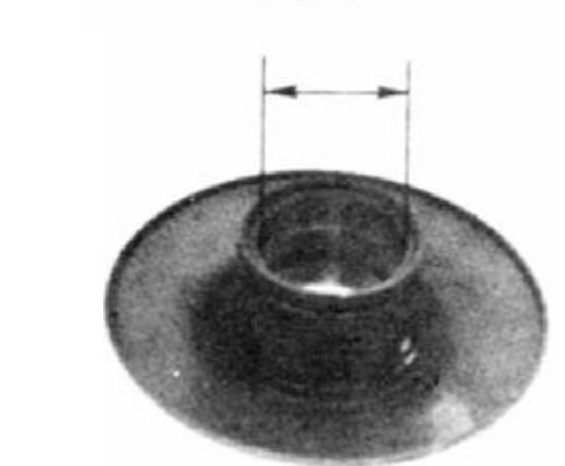

Final transmission gear removal.

Drain the gear oil

Remover the mission cover, gasket , and
dowel pin.



Remove the counter shaft and final shaft.

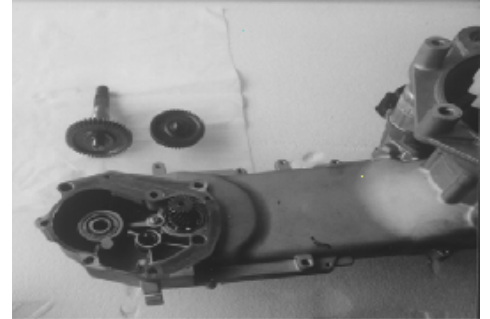

FINAL GEAR TRANSMISSION GEAR INSPECTION

Inspect the gears and shafts for wear or damage.

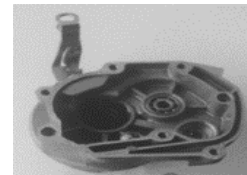

CRANKCASE REMOVAL

Remove the crankcase setting bolts.

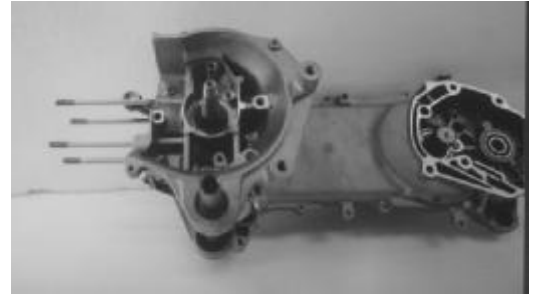

Remove the right crankcase from the left crankcase by using a pulley.

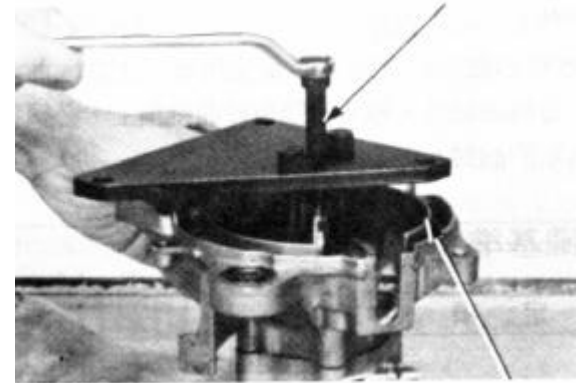

Remove the crankcase from the left crankcase by using a pulley.

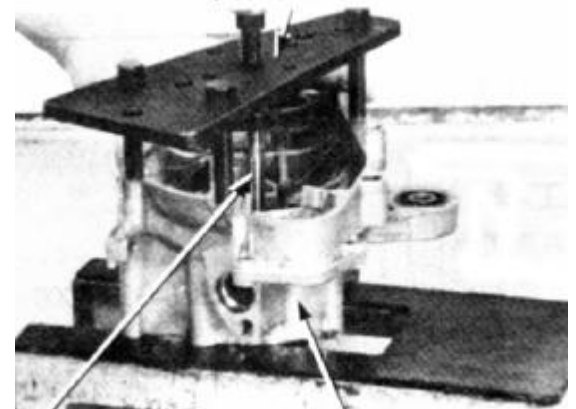

Remove the bearing of crankcase by using a bearing pulley.



CRANKSHAFT INSPECTION

Measure the connecting rod big end side clearance with a feeler gauge.

SERVICE LIMIT: 0.55 mm



Measure the connecting rod big end radial clearance at two different point across from each other.

SERVICE LIMIT: 0.05 mm

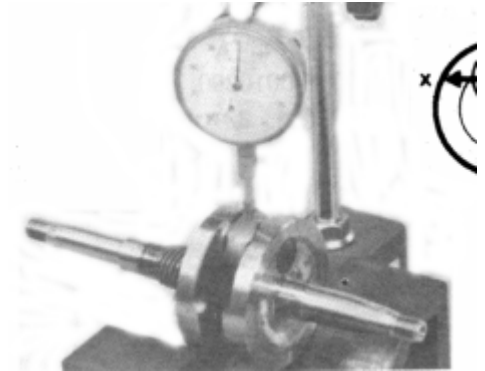

Place the crankshaft on a stand or V-blocks and measure the run out using a dial gauge. Actual bend is 1/2 of total indicator reading.

SERVICE LIMIT: 0.1 mm

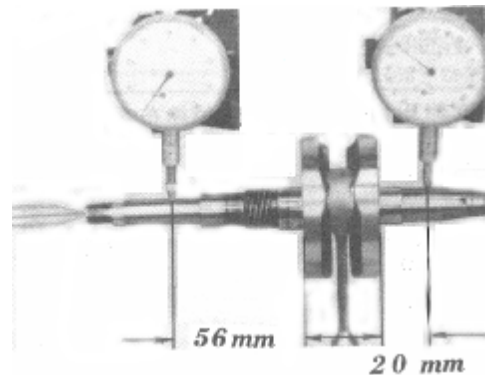

Check the crankshaft bearing play. If they are noisy or have recessive play, replace a new one.

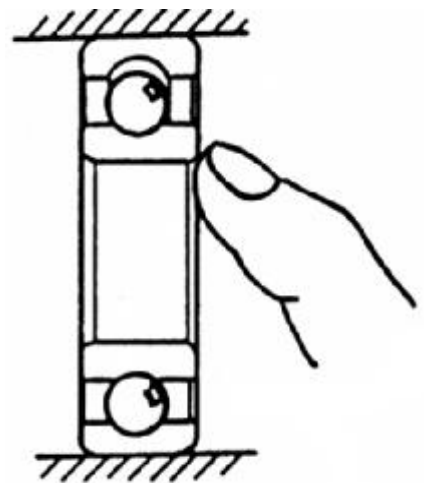

CRANKCASE INSTALLATION

Install the crankshaft bearing into the left crankcase.

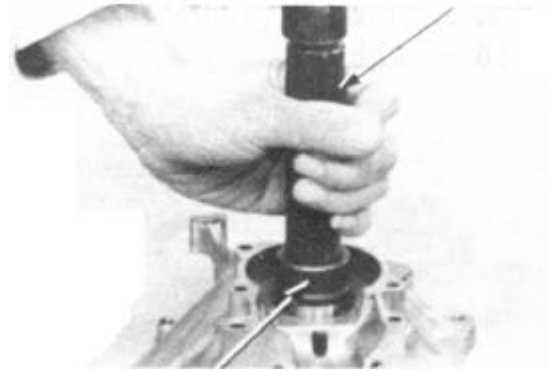

Install the crankshaft bearing into the right crankcase.

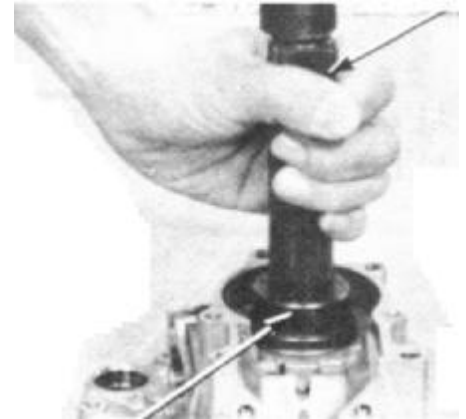

Install the crankshaft into the left crankcase.

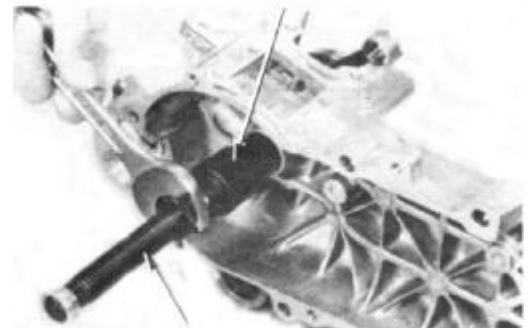

Install the oil seal into the left crankcase.

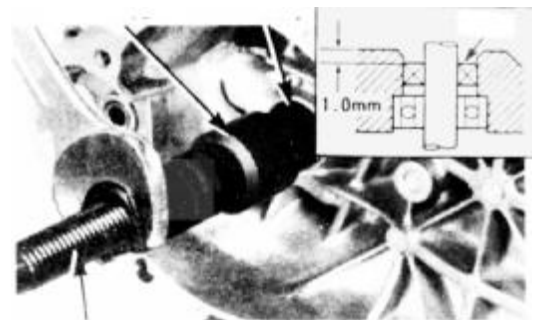

Install the dowel pins.

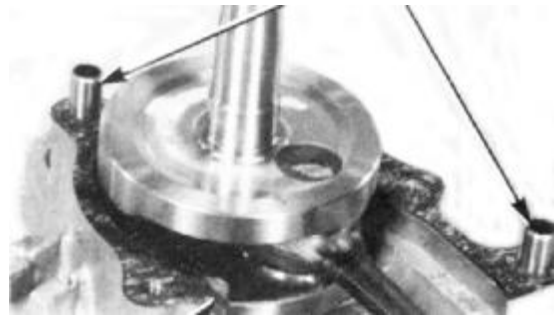

Install the right crankcase.

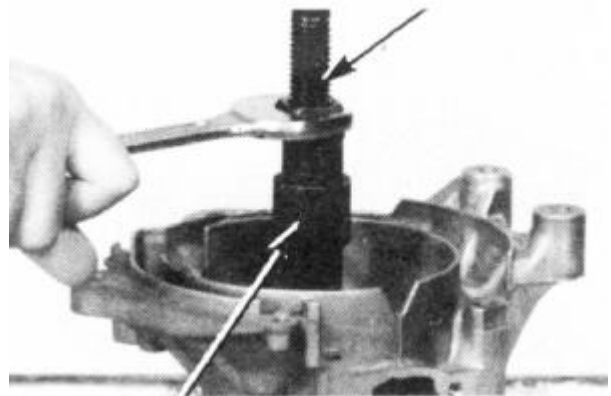

Install the oil seal into the right crankcase.

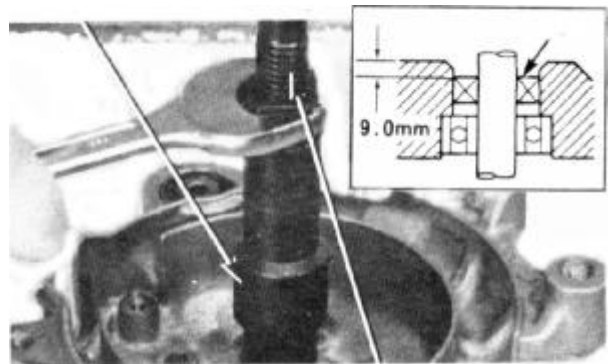

Install the setting bolts of crankcase.
TORQUE : 1.0 kg-m.

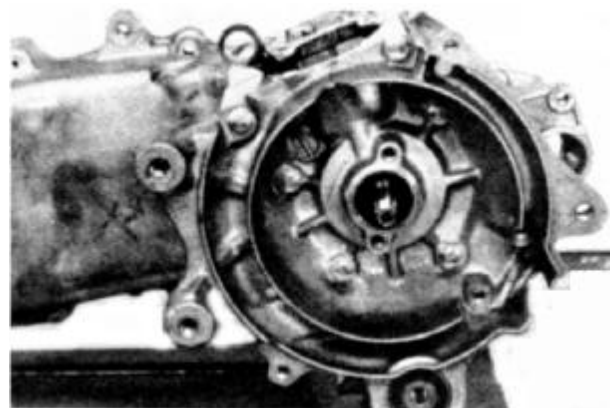

BATTERY INSPECTION

Check the voltage of the battery.

FULL CHARGE : 13.0~13.2 v

UNDER CHARGE : 12.3 v



BATTERY CHARGING

Connect charge position (+) cable to the battery positive terminal.

Connect the charge negative (-) cable to the battery negative (-) terminal.

CHARGING CURRENT : STANDARD : 0.4A

SWIFTNES : 4A

CHARGING TIME : STANDARD :5 hrs

SWIFTNES : 30 min

A.C.G. COIL INSPECTION

Check the continuity between the white and the green wire.

STANDARD :

Check the continuity between the yellow and the green wire.

STANDARD :

RESISTER INSPECTION

Check the continuity between the wire of resister and earth.

STNADARD :

RESISTER A :

RESISTER B :

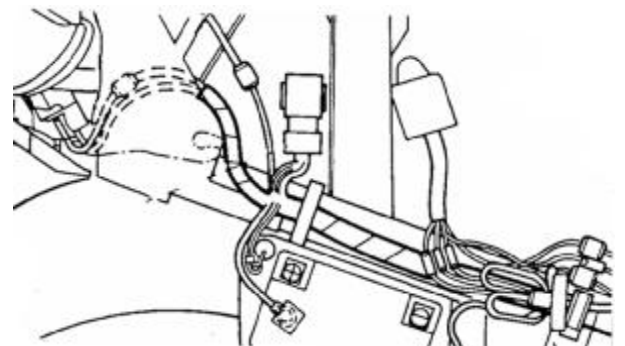
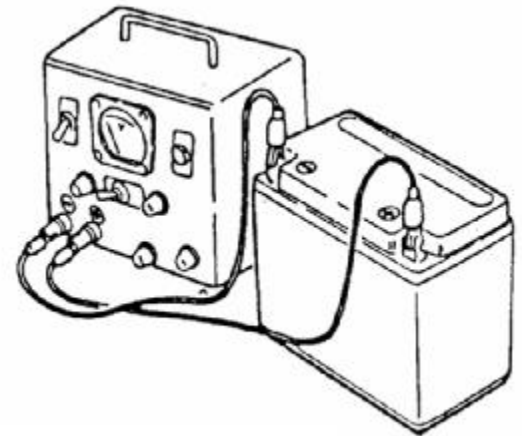

C.D. I. INSPECTION

		GOOD	NG
1.	OFF	NO SPARK	3/4
2.	P	-	3/4
3.	EXT	-	SPARK
4.	ON.1	SPARK	NO SPARK
5.	ON.2	-	-

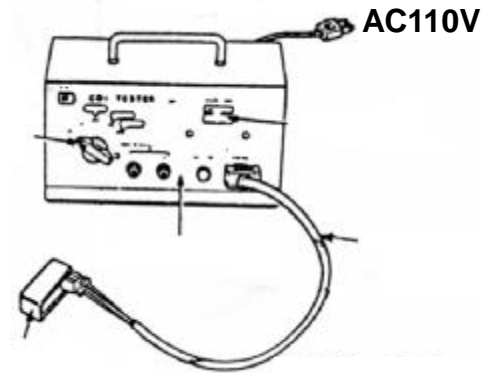

IGNITION COIL INSPECTION

Check the primary coil for continuity.
Mark connections with an ohmmeter as shown.

The coil is normal if there is continuity.

STANDARD: 0.1~1.0 W (20°C)

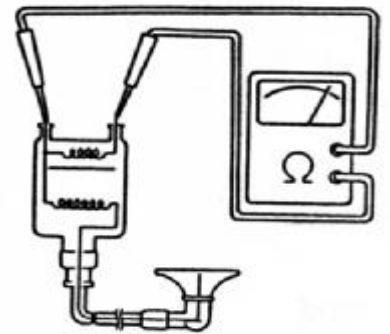

Check the secondary coil for continuity.
The ignite coil is correct if there is continuity.

STANDSRD:

With plug cap: 7~12 kW

No plug cap : 3~5 kW

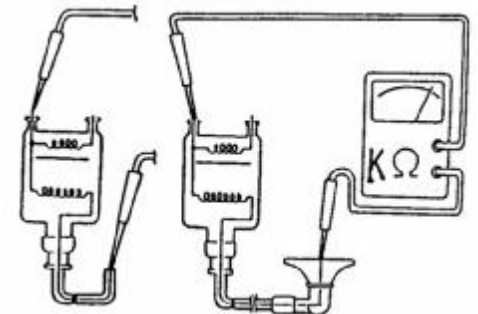

Check the coil output on a ignition coil tester.
Set the tester to ignition test, dial out the electrodes and observe the spark gap.

GOOD: Continuous spark.

NG: Discontinuous spark

NOTE:

Follow the instructions supplied with the tester.

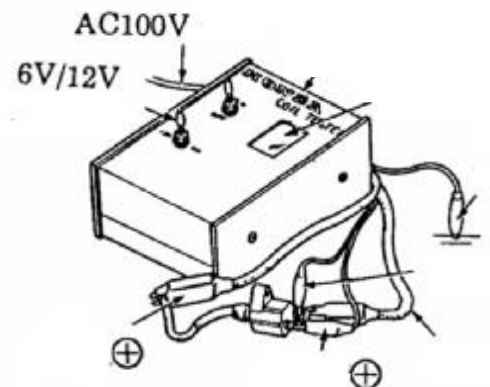

A. C. G. INSPECTION

EXCITER COIL INSPECTION

Disconnect the black / red wire of A. C. G.

Check the black / red and earth wire for continuity.

STANDARD: 300W ~1. KW (20°C)

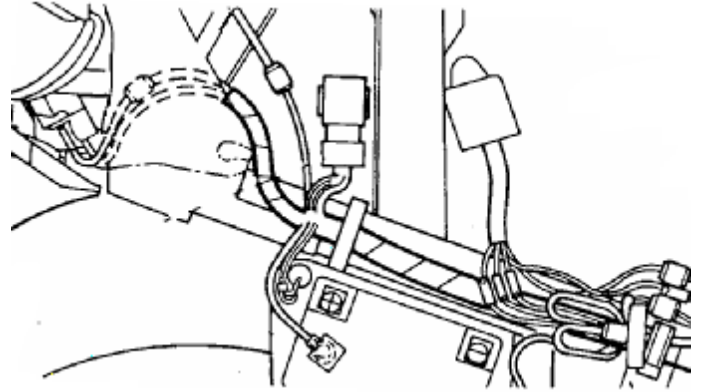

PLUSER COIL INSPECTION

Disconnect the blue / yellow wire of A. C. G.

Check the blue / yellow wire and green wire for continuity.

STANDARD: 40~300 W (20°C)

IGNITION TIMING INSPECTION

Check the ignition timing by using a timing light after warm up the engine.

STANDARD:

BTDC :13° ± 1°

(1700± 100rpm)

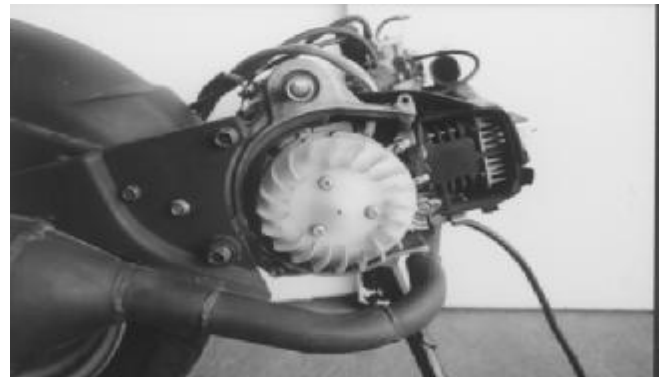

START MOTOR

START MOTOR INSPECTION

Connect a battery (12 V) to the motor.

Check the performance of the motor.

NOTE :

Use a fully charged battery.

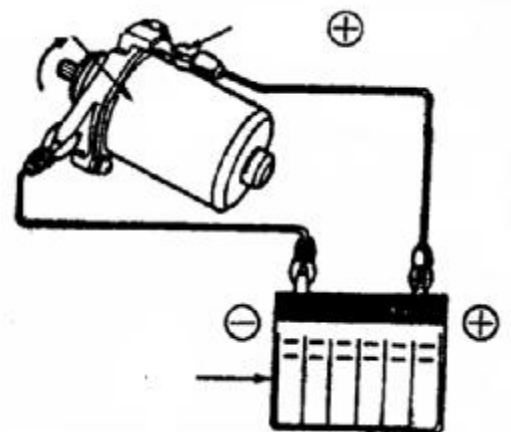

START RELLEY INSPECTION

Connect a battery (12V) between (D) and (C) as show.

Check the continuity between the (A) pole (B) pole.

GOOD : continuity

NG : discontinuity

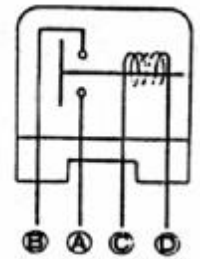
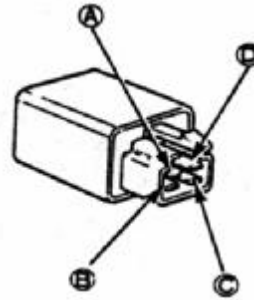
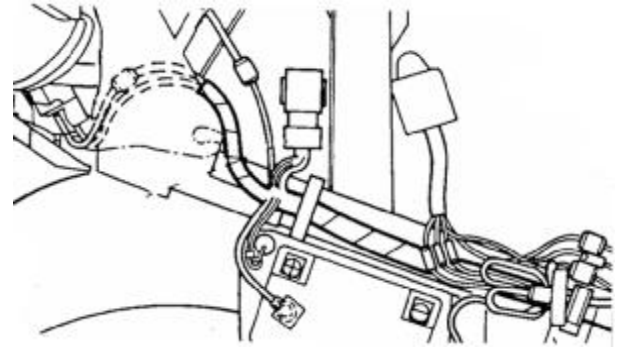

FUEL GAUGE INSPECTION

Check the fuel gauge for continuity as below :

	FLOAT UP	FLOAT DOWN
GREEN~YELLOW / WHITE	30~45W	500~850W
GREEN~BLUE / WHITE	400~700W	100~700W
YELLOW / WHITE~ BLUE / WHITE	450~750W	450~750W



FUEL INDICATOR INSPECTION

Remove the fuel gauge from the fuel tank.

Turn the main switch on.

Move the float from down to up if the guideline of indicator from "E" to "F".

Move the float from up to down if the guideline of indicator from "F" to "E".

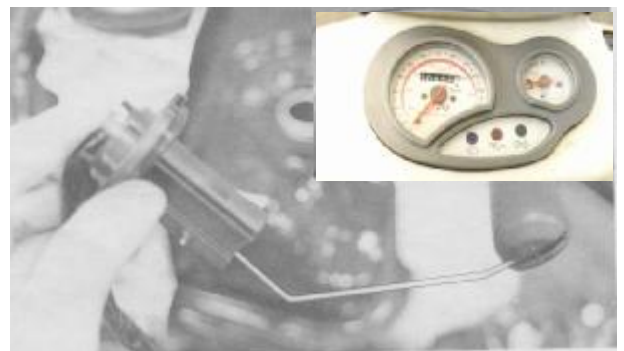

OIL LEVEL GAUGE REMOVAL

Remove the seat & luggage box.
Disconnect the gauge wire.
Remove the gauge.

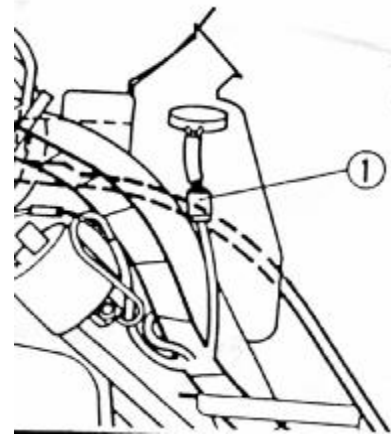

OIL LEVEL GAUGE INSPECTION

Check the continuity between the brown wire and gray wire as bellow.

OIL FLOAT POSITION		GOOD	NG		
A	UP	✓	i	✓	i
B	DOWN	i	✓	✓	i

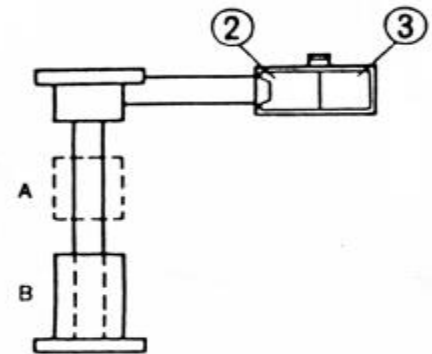

DIMMER SWITCH

POSITION \ COLOR	BLUE	WHITE	BULE / WHITE
HI		i — i	i — i
N	i — i	i — i	i — i
LO	i — i	i — i	i — i

START SWITCH

POSITION \ Color	YELLOW / RED	GREEN
OFF		
ON	i — i	i — i



HEAD LIGHT SWITCH

Color position	yellow / white	yello w	Black / Red	Umber / white	Peac h
OFF		i			i
(N)		i	i	i	
Y		i	i	i	
(N)	i	i	i		
Y	i	i	i		

TRUN SIDNAL SWITCH

COLOR position	ORANGE	LIGHT-BLUE	ASH
L		i	i
N			
R	i		i

HORE SWITCH BUTTON

COLOR POSITIO	GREEN	LIGHT / GREEN
OFF	i	i
ON		

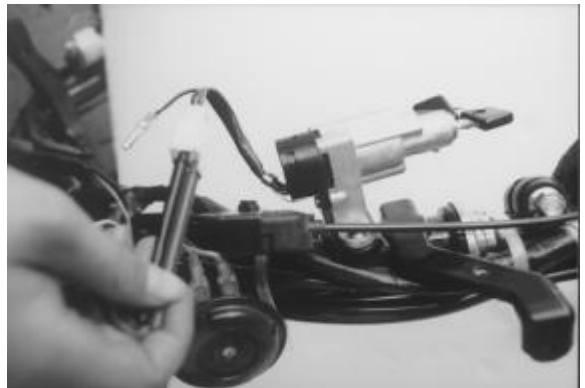

SWITCH INSPECTION MAIN SWITCH

COLOR POSITION	RED	BLACK / WHITE	GREEN	BLACK
OFF		i	i	
ON	i			i



METHOD TO REMOVE THE REAR WHEEL

1. REMOVE REAR FENDER.
 2. REMOVE EXHAUST PIPE
 3. REMOVE REAR WHEEL NUT.
 4. REMOVE THE REAR WHEEL.
 5. TO PUT IN THE REAR WHEEL:
OPPOSITE TO THE REMOVING OF IT
- TORQUE:**

M6:1.2-1.5kg-m

M8:2.2-3.0kg-m

M14:11.5-12.5kg-m



1. METHOD TO CHECK REAR BRAKE HUB
 - (1) MEASURE THE INTERNAL DIAMETER OF THE REAR BRAKE HUB
 - (2) USE LIMITATION: REPLACED WHEN OVER 110.5MM
2. METHOD TO CHECK BRAKE SHOE
 - (1) CHECK THE THICKNESS OF REAR BRAKE SHOE.
 - (2) USE LIMITATION: REPLACED WHEN UNDER 2.0MM

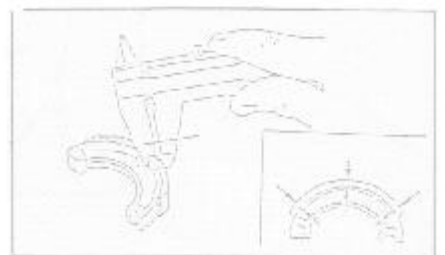
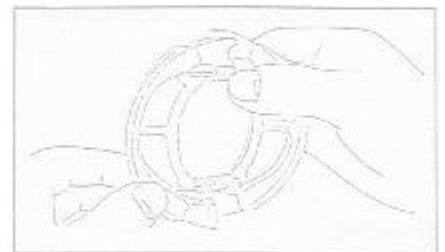

FRONT WHEEL REMOVAL

Raise the front wheel off the ground by placing a block or safety stand.
Disconnect the speedometer cable.
Remove the axle shaft.
Remove the front wheel.



AXLE SHAFT INSPECTION

Measure the axle shaft runout.
SERVICE LIMIT : 0.2 mm

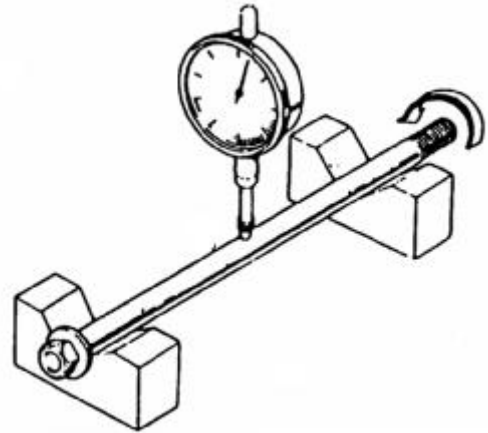

FRONT WHEEL RIM RUNOUT INSPECTION

Measure the wheel rim runout.
SERVICE LIMIT :
Radial: 2.0 mm
Axial: 2.0 mm

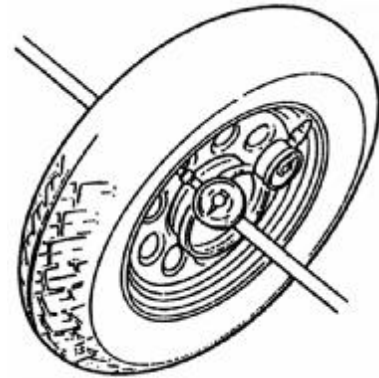

DISK BRAKE SYSTEM BRAKE OIL INSPECTION

Normal fluid level is between upper and lower.



BRAKE OIL CHANGING

Drain the brake oil by loosening the bleed nut.



Fill with new brake oil (DOT-3)
Release the air in the brake oil passage.

BRAKE LINING CHANGE

Remove the brake caliper setting bolts.
Remove the brake caliper.
Remove the brake lining setting bolts.
Remove the brake lining.

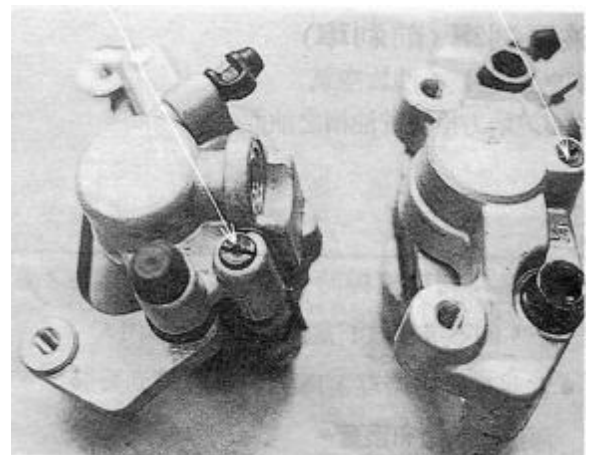

The installation sequence is essentially the reverse of removal.

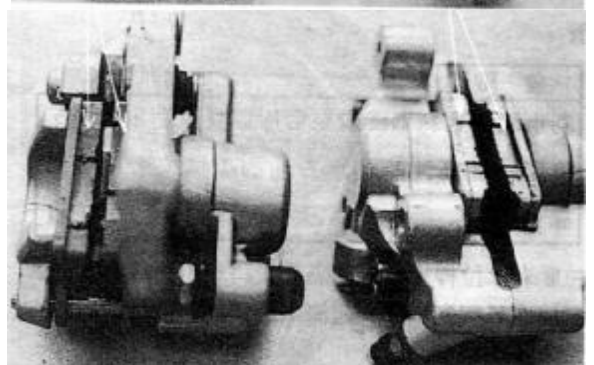

BRAKE DISK INSPECTION

Brake disc thickness.

SERVICE LIMIT : 3.0 mm

Brake disc flatness.

SERVICE LIMIT : 0.3 mm

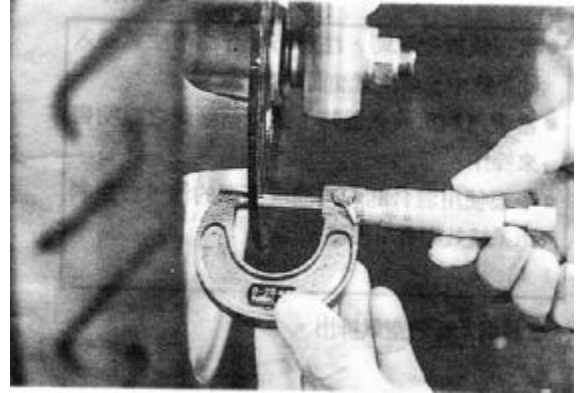

BRAKE MASTER CYLINDER REMOVAL

Drain the brake oil.

Remove the brake oil tube.

Remove the master cylinder.



DISASSEMBLY

Remove the cir-clip.

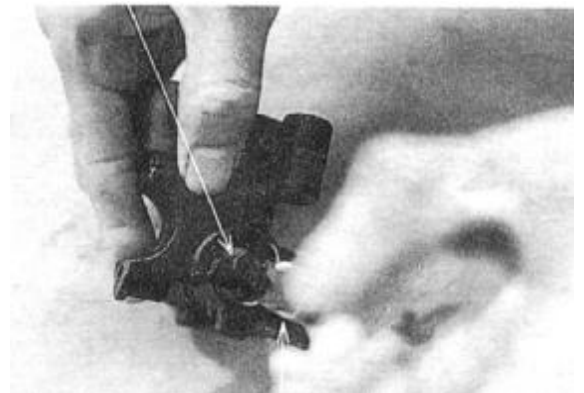

Remove the master cylinder kit.

Clean all the device.



INSPECTION

Inspect the master cylinder for wear or crack.

Measure the master cylinder I. D.

SERVICE LIMIT : 11.03mm



Measure the piston of master cylinder.

SERVICE LIMIT : 10.97mm

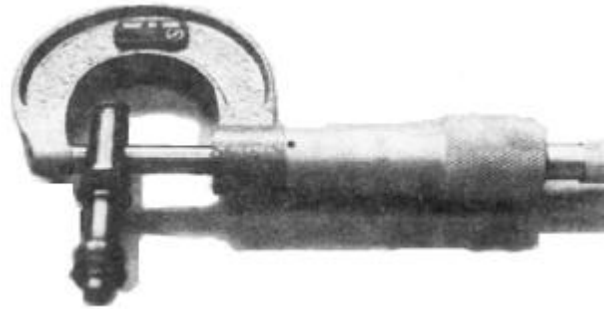

BRAKE CALIPER

REMOVAL

Remove the caliper from the front fork.

Disconnect the brake oil tube.



DISASSEMBLY

Remove the brake pad.

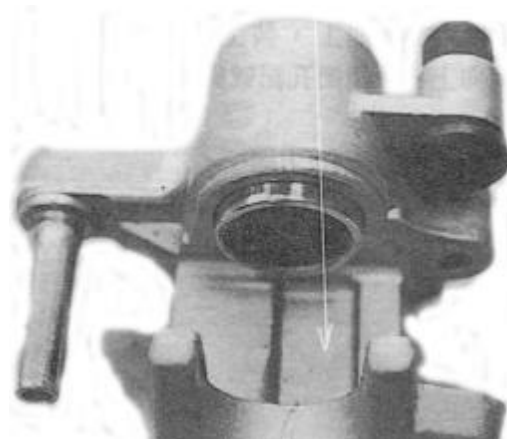

Remove the caliper piston.

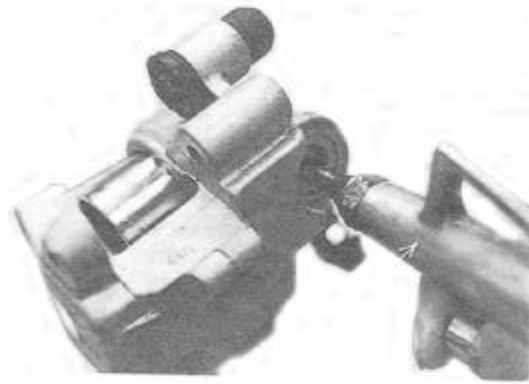

Remove the oil seal.

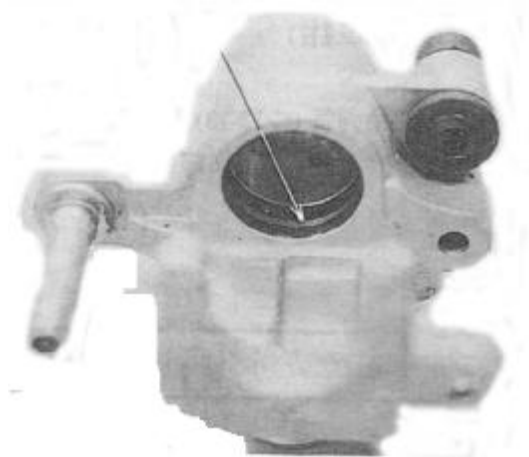

Measure the caliper cylinder I. D.
SERVICE LIMIT :30.25mm

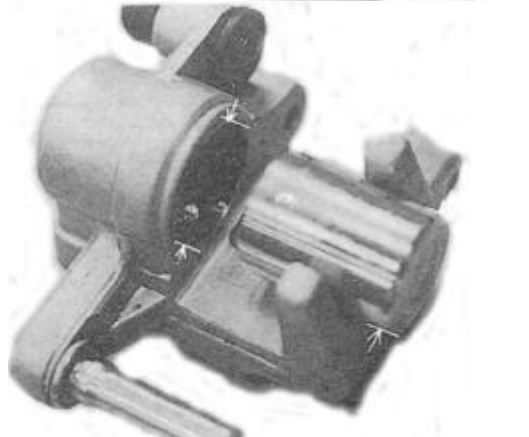

Measure the caliper PISTON O.D.
SERVICE LIMIT :30.20 mm



FRONT FORK REMOVAL

Remove the front wheel.
Remove the front for setting bolt.
Remove the front fork.

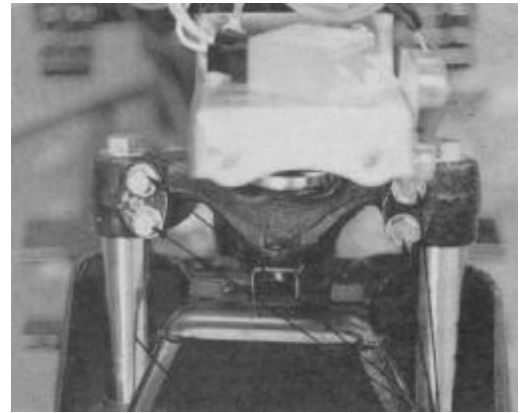

FRONT FORK DISASSEMBLY

Hold the fork tube in a vice.

NOTE :

Do not damage the fork tube while this operation.

Remove the fork bolt.
Remove the fork spring.

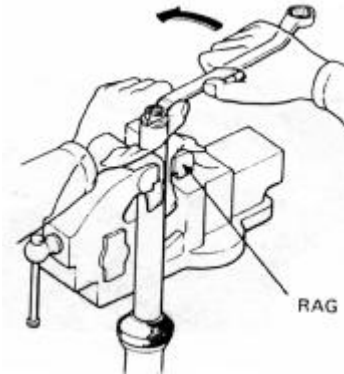

FRONT FORK INSPECTION

Measure the fork spring free length.

SERVICE LIMIT : 235.7 mm

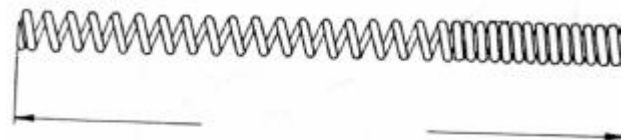

Drain the fork from the top of the front fork.
Pour out any remaining fluid by pumping the fork up and down several times.



Hold the bottom case in a vice.
Remove the socket bolt with an Allen wrench.
Remove the fork pipe, seat pipe and oil lock piece.
Check each part for wear or damage and replace if necessary.

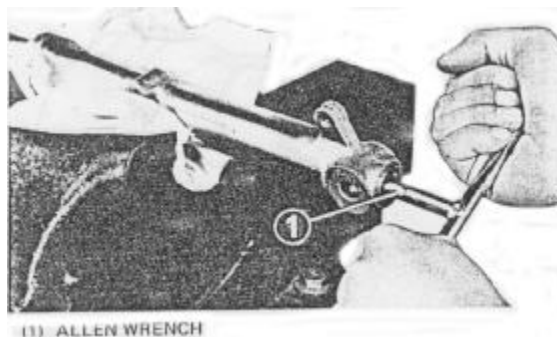

FORK TUBE INSPECTION

Place the fork tube in V-blocks and measure the runout with a dial indicator gauge.

The actual runout is 1/2 of TIR (*Total Indicator Reading*).

SERVICE LIMIT : 0.2 mm

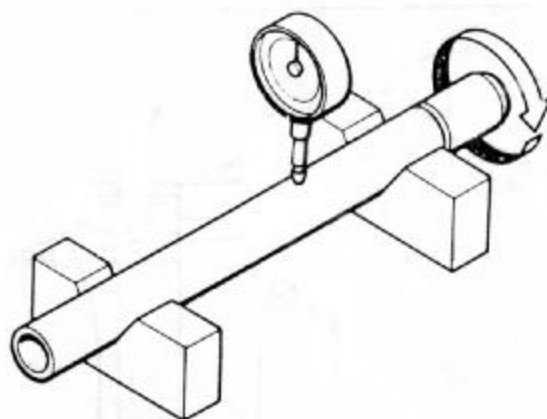

Measure the fork tube O. D. at the several points along the sliding surface.

SERVICE LIMIT : 30.9 mm

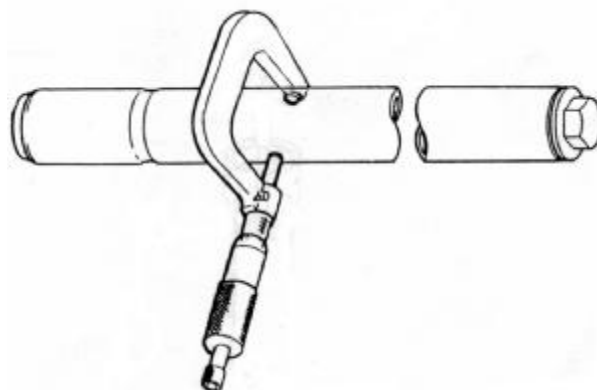

Remove the dust seal cover.
Remove the snap ring with a snap ring pliers.

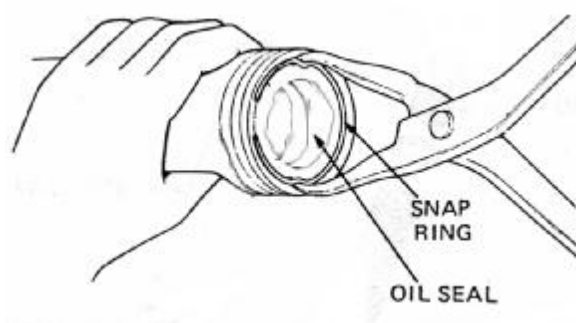

Remove the oil seal.

NOTE :

Avoid damaging the inner and outer surfaces of the slider when removing the seal and set ring.

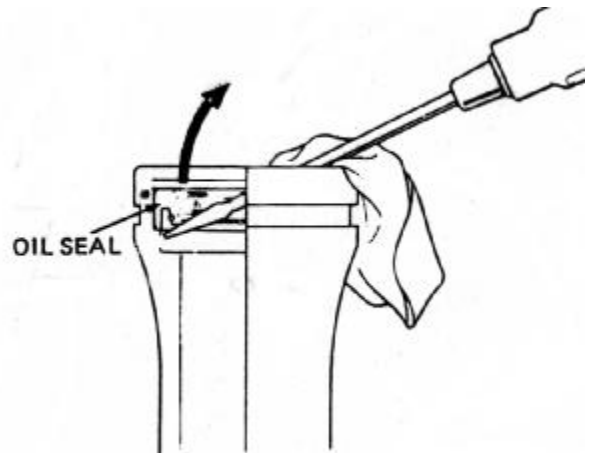

BOTTOM CASE INSPECTION

Check the inside sliding surface of the bottom case for wear or damage.

Measure the bottom case I. D.

SERVICE LIMIT : 31.1 mm



FRONT FORK ASSEMBLY

Before assembly, wash the parts in solvent and wipe them off completely.

Insert the seat pipe into the fork tube and set the oil lock piece on the end of the seat pipe.

Insert the parts into the fork slider and tighten the socket bolt with the 6 mm Allen wrench.

NOTE :

Apply locking agent to the socket bolt.

TORQUE : 1.8—2.3 kg-m

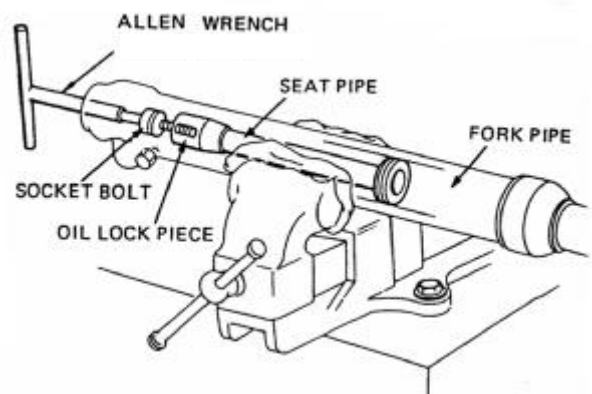

Install the oil seal in the top of the slider with a fork seal driver.

NOTE :

- **Apply ATF (Automatic Transmission Fluid) to the oil seal and install it with the fork seal driver.**
- **The fork seal is seated when the groove in the slider is visible at the top of the seal.**

Install the snap ring into the groove of the fork bottom case with snap ring pliers. Fill the forks with good quality ATF (Automatic Transmission Fluid).

CAPACITY : 61 cc

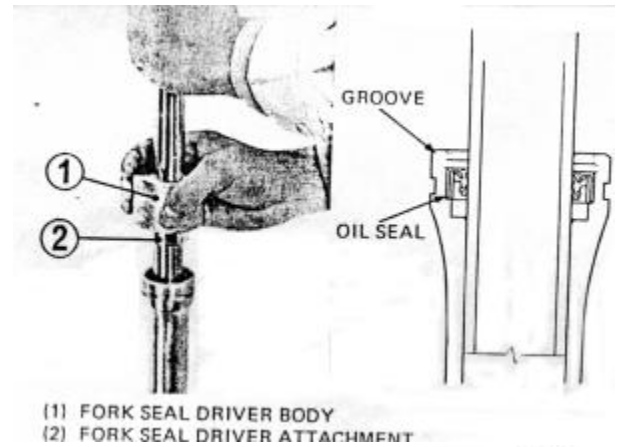

Install the fork spring into the fork tube.

NOTE :

Install the fork spring with the tightly wound coils facing up.

Hold the fork tube in a vice.

Tighten the fork bolt.

TORQUE : 4.0—5.0 kg-m

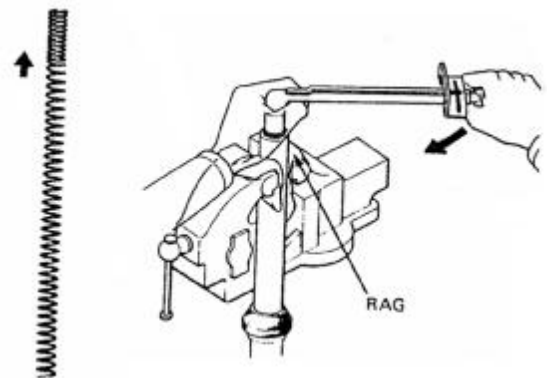

STEERING STEM REMOVAL

Remove the steering handle.

Remove the speedometer cable & front brake cable from the fork.

Remove the steering top thread nut.



Remove the steering top cone race.
Remove the front fork.



RON FORK INSTALATION

Grease the steel balls, ball races and cone races
Slide the steering stem through the steering head pipe from the bottom.



Install the steering top one race.



Install the steering top thread nut and tighten it until snug against the top cone race.

NOTE:

- Back the top thread nut out 1/8 turn after it is tightened snug Against the cone race.
- Make sure that there is no vertical movement and the stem and rotates freely.



Remove the steering top con race.
Remove the front fork.



RON FORK INSTALATION

Grease the steel balls, ball races and
cone races

Slide the steering stem through the
steering head pipe from the bottom.



Install the steering top one race.

